

## Application:

Navigation, GPS&Glonass, , etc...



## Features

SMD, high reliability, ultra Impact, Omni-directional...

## Part number

AAN 3216 - H2 P 1G59

(1) (2) (3) (4) (5)

(1)Product Type	Chip Antenna
(2)Size Code	3.2x1.6mm
(3)Type Code	H2
(4)Packing	Paper Tape
(5)Frequency	1.575&1.602GHz

## Electrical Specification

Working Frequency Range	1.575 ~1.602 GHz
Peak Gain	1.5 dBi (Typ.)
Impedance	50 Ohm
Return loss	10 dB ( Min)
Polarization	Linear
Azimuth Beamwidth	Omni-directional
Operation Temperature(°C)	-40 ~85°C

The specification is defined on EVB.

## Dimension and Terminal Configuration

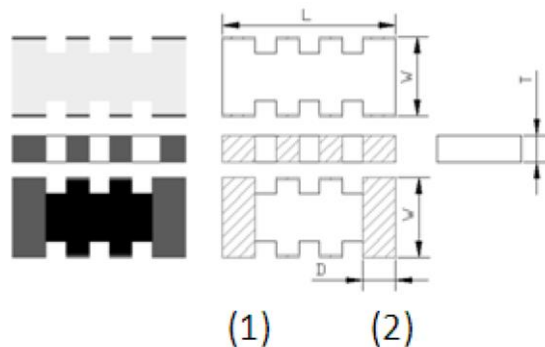

Dimension (mm)	
L	3.20±0.15
W	1.60±0.15
T	0.55±0.10
D	0.60±0.15

No.	Terminal Name
1	Feeding/Soldering
2	Soldering/Feeding

*P.S : Symmetrical,  
No direction*

### Evaluation Board Reference

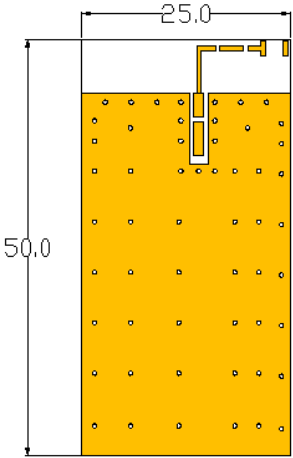
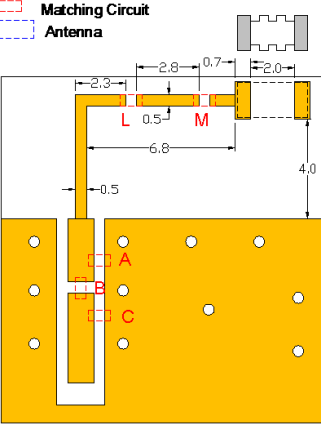
PCB Dimension	Antenna Layout Reference
 <p style="text-align: right;">unit : mm</p>	 <p style="text-align: right;">Unit : mm</p>

### Electrical Characteristics

#### Return Loss & Radiation

##### Return Loss

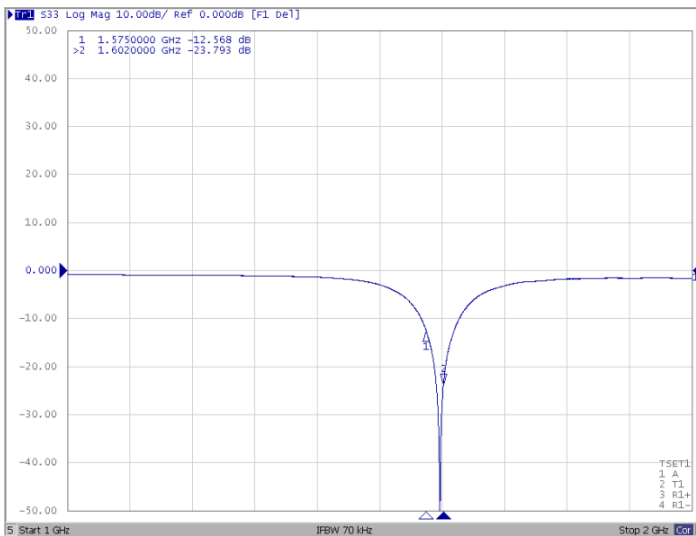

##### Matching Circuit

Matching Component		Value
A	Open	NA
B	Inductor	1nH
C	Inductor	2.7nH
L	Inductor	12nH
M	Inductor	15nH

Frequency (MHz)	S11 (dB)
1575	-12.6
1602	-23.8

##### Radiation

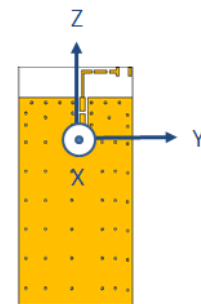
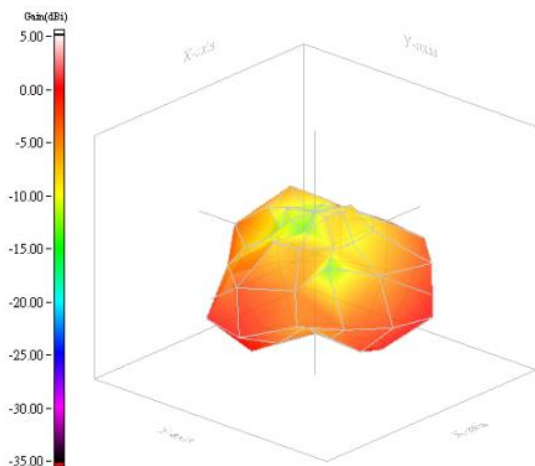

Frequency	1602MHz
Peak gain	1.5dBi
Average gain	-3.5dB
Efficiency	45.1%

**Taping Specifications**

**Reel and Taping Specification**

**Reel Specification**

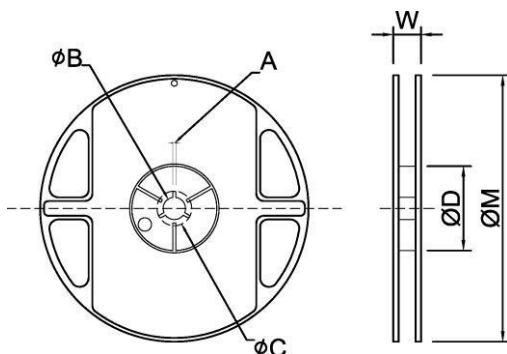

TYPE	SIZE		A	$\phi B$	$\phi C$	$\phi D$	W	$\phi M$
3216	7"	5K/Reel	2.0±0.5	13.5±1.0	21±1.0	60±1.0	11.5±2.0	178±2.0

**Tapping Specification**

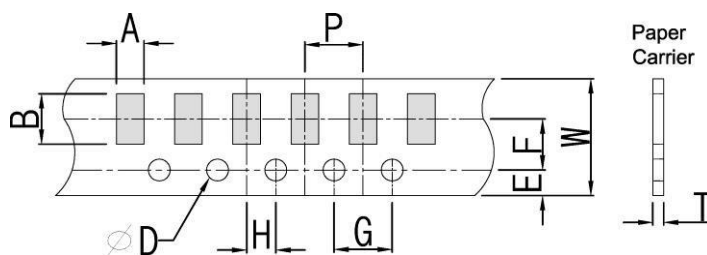

Packaging	Type	A	B	W	E	F	G	H	T	$\phi D$	P
Paper Type	3216	1.90±0.20	3.50±0.20	8.0±0.20	1.75±0.10	3.5±0.05	4.0±0.10	2.0±0.05	0.75±0.10	1.50 +0.10 -0	4.0±0.1

## Reliability Table

Test Item	Procedure	Requirements Ceramic Type	Remark (Reference)
<b>Electrical Characterization</b>		Fulfill the electrical specification	User Spec.
<b>Thermal Shock</b>	1. Preconditioning: $50 \pm 10^{\circ}\text{C}$ / 1 hr, then keep for $24 \pm 1$ hrs at room temp. 2. Initial measure: Spec: refer Initial spec. 3. Rapid change of temperature test: $-30^{\circ}\text{C}$ to $+85^{\circ}\text{C}$ ; 100 cycles; 15 minutes at Lower category temperature; 15 minutes at Upper category temperature.	No Visible Damage. Fulfill the electrical specification.	MIL-STD-202 107
<b>Temperature Cycling</b>	1. Initial measure: Spec: refer Initial spec. 2. 100 Cycles ( $-30^{\circ}\text{C}$ to $+85^{\circ}\text{C}$ ), Soak Mode=1 (2 Cycle/hours). 3. Measurement at $24 \pm 2$ Hours after test condition.	No Visible Damage. Fulfill the electrical specification.	JESD22 JA104
<b>High Temperature Exposure</b>	1. Initial measure: Spec: refer Initial spec. 2. Unpowered; 500hours @ $T=+85^{\circ}\text{C}$ . 3. Measurement at $24 \pm 2$ hours after test.	No Visible Damage. Fulfill the electrical specification.	MIL-STD-202 108
<b>Low Temperature Storage</b>	1. Initial measure: Spec: refer Initial spec. 2. Unpowered: 500hours @ $T=-30^{\circ}\text{C}$ . 3. Measurement at $24 \pm 2$ hours after test.	No Visible Damage. Fulfill the electrical specification.	MIL-STD-202 108
<b>Solderability (SMD Bottom Side)</b>	Dipping method: a. Temperature: $235 \pm 5^{\circ}\text{C}$ b. Dipping time: $3 \pm 0.5\text{s}$	The solder should cover over 95% of the critical area of bottom side.	IEC 60384-21/22 4.10
<b>Soldering Heat Resistance (RSH)</b>	Preheating temperature: $150 \pm 10^{\circ}\text{C}$ . Preheating time: 1~2 min. Solder temperature: $260 \pm 5^{\circ}\text{C}$ . Dipping time: $5 \pm 0.5\text{s}$	No Visible Damage.	IEC 60384-21/22 4.10
<b>Vibration</b>	5g's for 20 min., 12 cycles each of 3 orientations Note: Use 8"X5" PCB .031" thick 7 secure points on, one long side and 2 secure points at corners of opposite sides. Parts mounted within 2" from any secure point. Test from 10-2000 Hz.	No Visible Damage.	MIL-STD-202 Method 204
<b>Mechanical Shock</b>	Three shocks in each direction shall be applied along the three mutually perpendicular axes of the test specimen (18 shocks) Peak value: 1,500g's Duration: 0.5ms Velocity change: 15.4 ft/s Waveform: Half-sine	No Visible Damage.	MIL-STD-202 Method 213
<b>Humidity Bias</b>	1. Humidity: 85% R.H., Temperature: $85 \pm 2^{\circ}\text{C}$ . 2. Time: $500 \pm 24$ hours. 3. Measurement at $24 \pm 2$ hrs after test condition.	No Visible Damage. Fulfill the electrical specification.	MIL-STD-202 Method 106

<p><b>Board Flex (SMD)</b></p>	<p>1. Mounting method: IR-Reflow. PCB Size (L:100 x W:40 x T:1.6mm) 2. Apply the load in direction of the arrow until bending reaches 2 mm.</p>	<p>No Visible Damage.</p>	<p>AEC-Q200 005</p>
<p><b>Adhesion</b></p>	<p>Force of 1.8Kg for 60 seconds.</p>	<p>No Visible Damage Magnification of 20X or greater may be employed for inspection of the mechanical integrity of the device body terminals and body/terminal junction.</p>	<p>AEC-Q200 006</p>
<p><b>Physical Dimension</b></p>	<p>Any applicable method using x10 magnification, micrometers, calipers, gauges, contour projectors, or other measuring equipment, capable of determining the actual specimen dimensions.</p>	<p>In accordance with specification.</p>	<p>JESD22 JB100</p>

**Revision History**

Revision	Date	Content
1	2017/11/15	New issue