



炬鹿科技有限公司  
RIDEE TECH COMPANY LIMITED

Revision Date : 2023 / 11 / 15

# APPROVAL SHEET

Product Name : Metal Strip Low Ohm - Long Terminal Resistor

Part No. : RWL Series

Description : Size 0508

炬鹿科技有限公司

RIDEE TECH COMPANY LIMITED

For more contact information, please refer to our website: [www.rideetech.com](http://www.rideetech.com)

### Metal Strip Low Ohm - Long Terminal Resistor - RWL Series

#### ■ Applications

- Switching model power supply.
- Notebook, Tablet PC
- Battery pack.
- Power Amplifier
- Test Instrument.



#### ■ Features

- Extra Low Ohm and Precision ( $\pm 0,5\%$ )
- High Power Up to 4 Watts
- Low Inductance design
- RoHS Compliant

#### ■ Part Number Explanation

RWL	0508	2	07	F	R002	T	SB
Product	Size (Inch)	Terminal	Watt	Tolerance	Resistance	Packaging	Functional
Metal Strip Low Ohm - Long Terminal Resistor	0508	2 :2 terminals	07 : 3/4W 10 : 1W	F = $\pm 1\%$ G = $\pm 2\%$ J = $\pm 5\%$	R005=5m $\Omega$ R002=2m $\Omega$	T= Tape & Reel	SB= Standard Type (Low EMF)  MB= Meet AEC-Q200 (Low EMF)

### Standard Electrical Specifications

Item Type	Type of Terminal	Rated Power (W)	Max Working Current	Max Overload Current	T.C.R. (PPM/°C)	Alloy Type	Resistance Range
							F(± 1%) , G(±2%) , J(± 5%)
RWL 0508	2	3/4 W	27.38A	44.76A	±100	Low EMF	$1\text{m}\Omega \leq R \leq 1.5\text{m}\Omega$
			19.36A	38.72A	±50		$2\text{m}\Omega \leq R \leq 5\text{m}\Omega$
		1 W	31.62A	63.24A	±100	Low EMF	$1\text{m}\Omega \leq R \leq 1.5\text{m}\Omega$
			22.36A	44.72A	±50		$2\text{m}\Omega \leq R \leq 5\text{m}\Omega$

- Rating Terminal Temperature: 105°C (do not exceed 105°C when working)
- Beyond the above specification also can meet the special requirements. For detailed questions, please contact us freely.

### Dimension

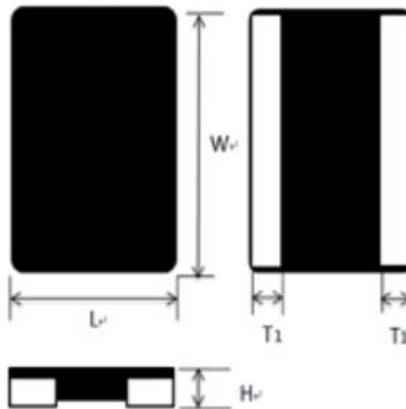

Unit: mm

Size	Type of Terminal	Power Rating (W)	Resistance Range (mΩ)	L	W	H	T1
0508	2	3/4 1	1	1.25±0.20	2.00±0.20	0.40±0.10	0.38±0.15
			1.5 ~ 5				0.32±0.15

### ■ Performance Characteristics

#### ■ Power Derating Curve

Operating Temperature Range: -55 to +155°C

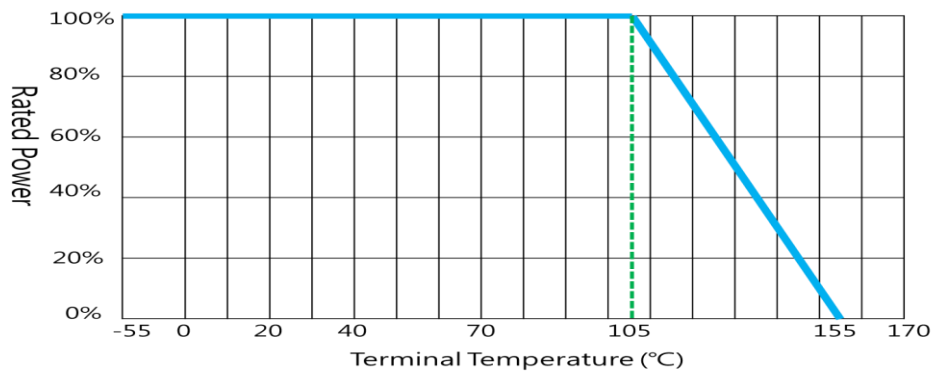
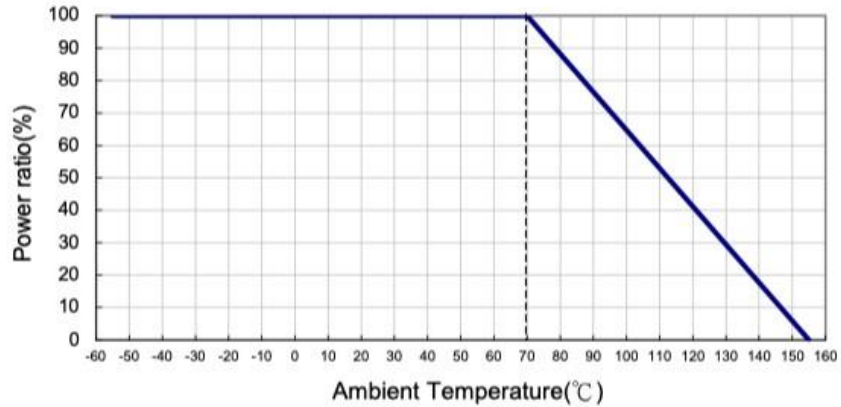

#### ■ Voltage Rating or Current Rating

Resistance Range:  $\geq 1\Omega$

Rated Voltage: The resistor shall have a DC continuous working voltage or a RMS AC continuous working voltage at commercial-line frequency and wave form corresponding to the power rating, as determined formula as following:

$$E(RCWV) = \sqrt{P \times R}$$

E=Rated voltage(V)

P=Power rating(W)

R=Nominal resistance( $\Omega$ )

### ■ Soldering Conditions

Soldering Reference : Applicable for most industrial soldering request.  
 Compatible with reflow soldering. (Not compatible with wave soldering)

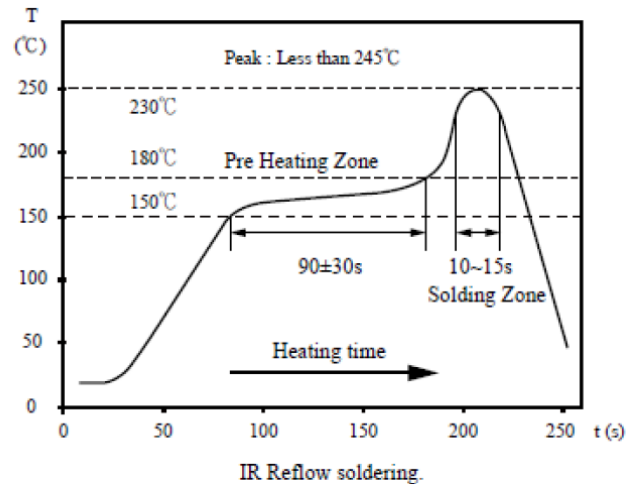

### ■ Recommend Solder Pad Dimensions

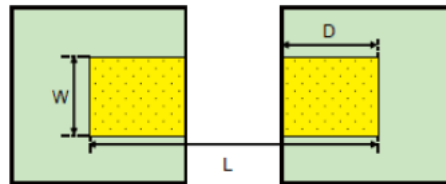

Unit: mm

Type	Resistance (mΩ)	W	D	L
0508	1	2.30	0.90	2.20
	1.5~5	2.30	0.85	2.20

### Reliability Test and Requirement

Test Item	Test Method	Procedure	Requirements
Temperature Cycling	AEC-Q200 TABLE 7.4 IEC 60115-1 Clause 4.19	<b>AEC-Q200 TABLE 7.4</b> 1000 Cycles (-55°C to +125°C) Measurement at 24± 4 hours after test conclusion.  <b>IEC 60115-1 Clause 4.19 for General Type</b> Repeat 5 cycles as follows -55°C (30min.)→25°C (2~3min.)→155°C (30min.)→25°C (2~3min.)	$\Delta R \leq 1\%$ No mechanical damage
Resistance to Solder Heat	AEC-Q200 TABLE 7.15	Solder dipping @ 260°C±5°C for 10sec.±1sec.	$\Delta R \leq 1\%$ No mechanical damage
Biased Humidity	AEC-Q200 TABLE 7.7	1000 hours 85°C/85%RH.10% of operation power. Measure at 24 ±2 hours after test end.	$\Delta R \leq 1\%$
High Temperature Exposure (Storage)	AEC-Q200 TABLE 7.3	1000 hrs. T=155°C Unpowered. Measure at 24 ±2 hours after test end.	1~ 3 mΩ: $\Delta R \leq \pm 1\%$ 4~5 mΩ: $\Delta R \leq \pm 2\%$
Operation Life	AEC-Q200 TABLE 7.8	Test 1000hr @ TA=125 °C at specified rated power. Measurement at 24±2 hours after test end.	$\Delta R \leq \pm 2\%$
External Visual	AEC-Q200 TABLE 7.9	Inspect appearance, marking and workmanship.	No visual damage and refer Ridee marking code.
Mechanical Shock	AEC-Q200 TABLE 7.13	Test Peak value: 100g's, Wave: Half-sine, Duration: 6ms, Velocity: 12.3ft/sec.	Within product specification tolerance and no visible damage
Vibration	AEC-Q200 TABLE 7.14	5 g's for 20 min., 12 cycles each of 3 orientations. Test from 10-2000 Hz.	$\Delta R \leq \pm 1\%$ No mechanical damage.
ESD	AEC-Q200-002	Test contact min. 1KV.	$\Delta R \leq \pm 1\%$ No mechanical damage.
Solderability	AEC-Q200 TABLE 7.18 IEC 60115-1, Clause 4. 17	<b>AEC-Q200 TABLE 7.18</b> a) Baking 155°C 4H, dipping 235°C 5s b) Steam 8H, dipping 215°C 5s c) Steam 8H, dipping 260°C 7s  <b>IEC 60115-1, Clause 4. 17 for General Type</b> After immersing flux, dip in the 245±2°C molten solder bath for 3±0.5 sec.	Over 95% of termination must be covered with solder.
Thermal Shock	AEC-Q200 TABLE 7.16	-55 to 155°C/ dwell time 15min/ Max transfer time 20sec/ 300cycles.s	$\Delta R \leq \pm 1\%$ No mechanical damage.
Board Flex	AEC-Q200 TABLE 7.21	Bending 2mm. for 60 seconds	$\Delta R \leq \pm 1\%$ No mechanical damage.
Short Time Overload	IEC 60115-1, Clause 4. 13	4 x Rated power for 5 seconds	$\Delta R \leq \pm 1\%$

### ■ Packaging Information

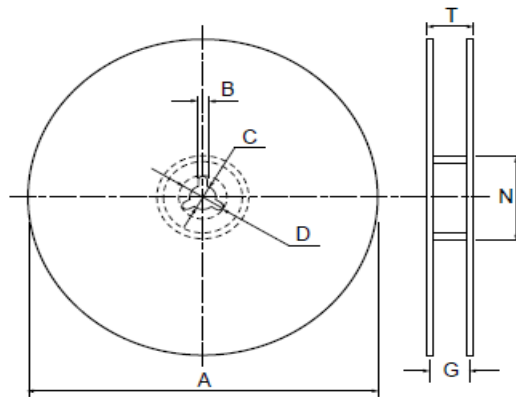

Unit:mm

Size	Packaging Q'ty	A	N	C	D	B	G	T
0508	5K/Reel	178±2.0	60.0±0.5	13.0±0.5	20(Min.)	2.0±0.5	10.0±1.5	14.9max

### ■ Tapping Specification

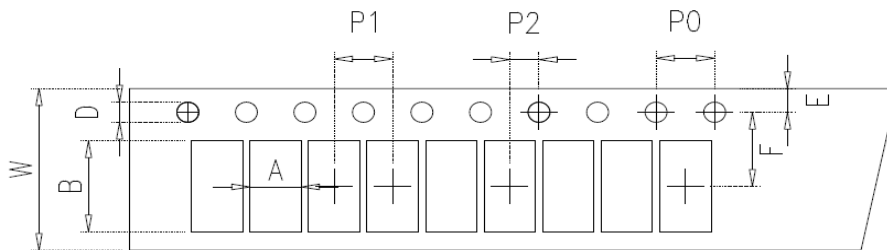

Unit:mm

Packaging	Size	A	B	W	E	F	P0	P1	P2	D
Paper Type	0508	2.40±0.20	1.65±0.20	8.0±0.3	1.75±0.1	3.5±0.05	4.0±0.1	4.0±0.1	2.0±0.05	1.50+0.10/-0

### ■ Marking

- RWL0508 : No Marking